

RJ31X-Kit Installation Guide

Included:

1. RJ31X wall mount block with pigtail
2. 10 Blue Crimp Connectors
3. Rescue Alert RJ31X Cable (8-pin plug on each end)
4. Wiring Diagrams (6)
5. Instructions

Overview:

The RJ31X-Kit allows the RA400 Personal Emergency Response System to call for help when activated even when another telephone extension is off-hook in the house.

After installation of the RJ31X, all of your telephones in the house should work normally with or without the RA400 connected. **Remember not to connect any device other than the RA400 to the RJ31X jack.** Doing so will cause all of your telephones in the house to stop working. To connect the RA400 to the RJ31X jack, you must use the Rescue Alert RJ31X Cable supplied in the RJ31X-Kit that has the wide 8-pin plug on each end.

Installation is straightforward. After determining where the RA400 is to be installed (near a telephone jack and AC outlet) the RJ31X is mounted to the wall near the existing RJ11 jack.

If there are multiple telephone jacks in the house, determine which one is the entry point, in other words, the jack in the house that connects directly to the telephone company feed.

Depending on where the entry point is in relation to the RA400 location follow the appropriate wiring diagram to properly connect the RJ31X jack.

Blue Crimp Connectors:

Use the blue crimp connectors to splice two or more wires together. First strip each wire about 3/8". Insert each wire completely into the open end of a connector. Squeeze the connector flat with pliers to make a secure connection.

Diagram Descriptions:

There are six wiring diagrams supplied in the kit. The first two show the most common wiring schemes used to wire residential telephones.

First determine which of Figure-1 or Figure-2 is representative of your home.

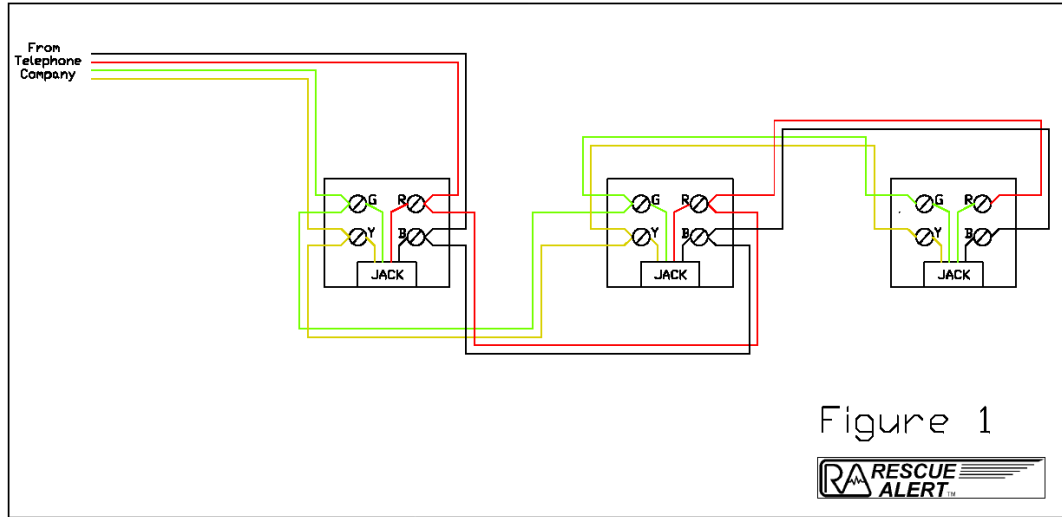

Figure-1 shows a typical wiring diagram of a home where the feed from the telephone company is connected to a jack and then daisy chained to each additional jack in the home. Typically the YELLOW and BLACK wires are not used and may not even be connected.

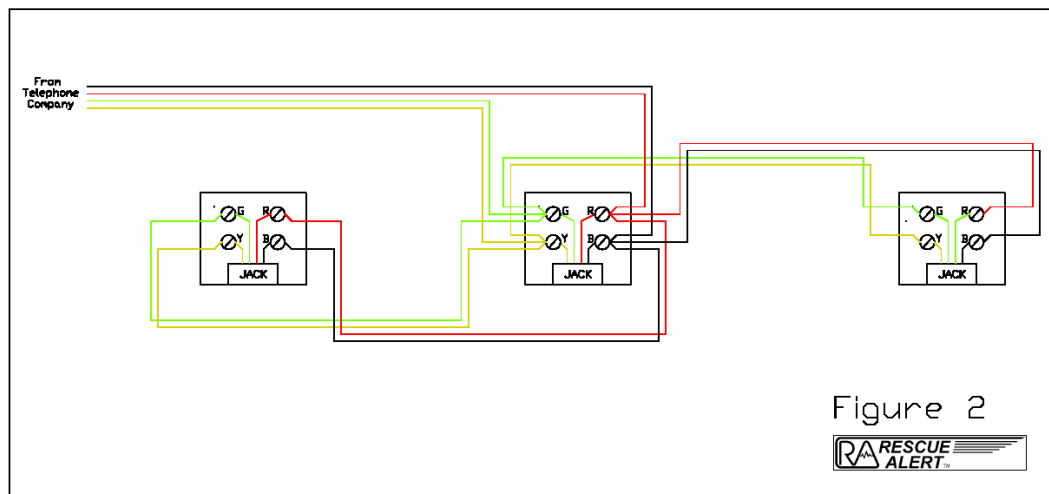

Figure-2 shows a typical wiring diagram of a home where the feed from the telephone company is connected to a jack and branches off to more than one jack in the home. Typically the YELLOW and BLACK wires are not used and may not even be connected.

If your home is wired in a daisy chain fashion as shown in Figure-1, use either Figure-1a or Figure-1b, depending on where the RJ31X jack is to be installed.

If your home is wired in a branch as shown in Figure-2, use either Figure-2a or Figure-2b, depending on where the RJ31X jack is to be installed.

Daisy Chain

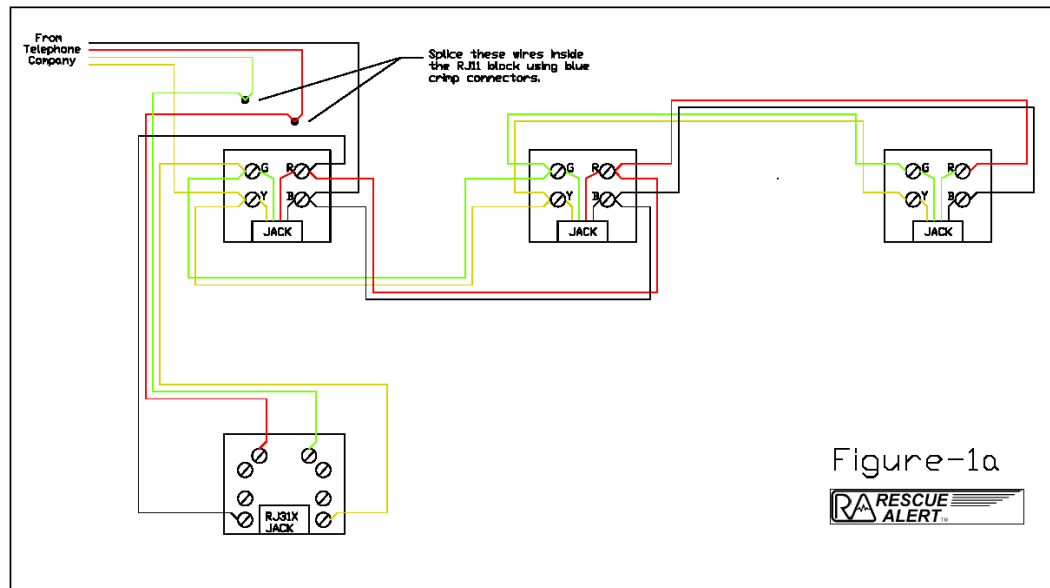

Figure-1a shows an RJ31X jack installed near the entry jack in a home originally wired as shown in Figure-1.

Instructions:

1. Mount the RJ31X jack on the wall near the existing RJ11 jack using the double back tape supplied with the new jack.
2. Remove the cover of the existing RJ11 jack.
3. Disconnect the RED and GREEN wires coming from the telephone company. Now all telephones in the house should be dead. If any telephone still works, the two wires disconnected are not the feed from the telephone company. Reconnect them and find the correct pair.
4. Splice the loose RED and GREEN wires to the RED and GREEN wires coming from the RJ31X jack using two blue crimp connectors.

5. Connect the YELLOW and BLACK wires from the RJ31X jack to the terminals where the original RED and GREEN feed wires were connected. All telephones in the house should now be operational again.
6. Tuck the wires back into the RJ11 housing and replace the cover.
7. Connect the RA400 to the new RJ31X jack using the RA400 RJ31X Cable supplied in the kit.

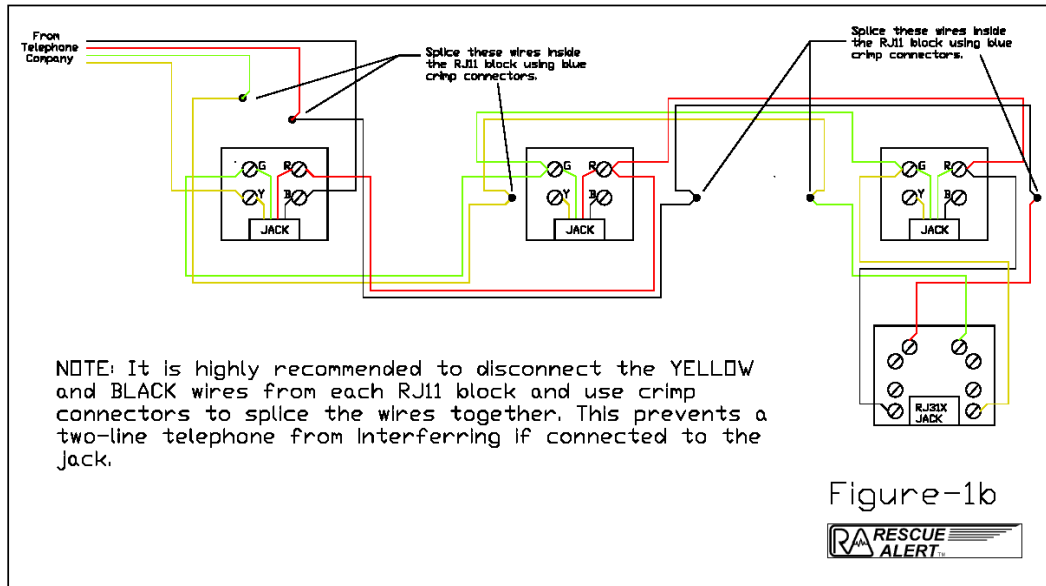

Figure-1b shows an RJ31X jack installed near a jack other than the entry jack in a home originally wired as shown in Figure-1.

Instructions:

1. Mount the RJ31X jack on the wall near the desired RJ11 jack using the double back tape supplied with the new jack.
2. Remove the cover of the RJ11 jack.
3. At the entry jack, disconnect the RED and GREEN wires coming from the telephone company. Now all telephones in the house should be dead. If any telephone still works, the two wires disconnected are not the feed from the telephone company. Reconnect them and find the correct pair.
4. Also at the entry jack, remove the YELLOW and BLACK wires leaving the jack going to the next jack in the daisy chain. Cut the bare ends off so that they cannot short or touch any other connection.

5. Splice the loose RED wire to the loose BLACK wire and the loose GREEN wire to the loose YELLOW wire using two blue crimp connectors.
6. At the next jack in the daisy chain, remove each YELLOW and each BLACK wire and splice the wires together as shown in Figure-1b. Repeat this step for all jacks in the house except the jack where the RJ31X is being installed.
7. At the jack where the RJ31X is being installed, disconnect the YELLOW and BLACK wires from the RJ11.
8. Splice the YELLOW wire that was just disconnected to the GREEN wire that is coming from the RJ31X using a blue crimp connector as shown in Figure-1b.
9. Splice the BLACK wire that was just disconnected to the RED wire coming from the RJ31X using a blue crimp connector as shown in Figure-1b.
10. Connect the BLACK wire from the RJ31X jack to the RED terminal of the RJ11 jack as shown in Figure-1b.
11. Connect the RED wire from the RJ31X jack to the GREEN terminal of the RJ11 jack as shown in Figure-1b.
12. At this point, each telephone in the house should be operational.
13. Tuck the wires back into all of the RJ11 housings and replace the covers.
14. Connect the RA400 to the new RJ31X jack using the RA400 RJ31X Cable supplied in the kit.

Branch

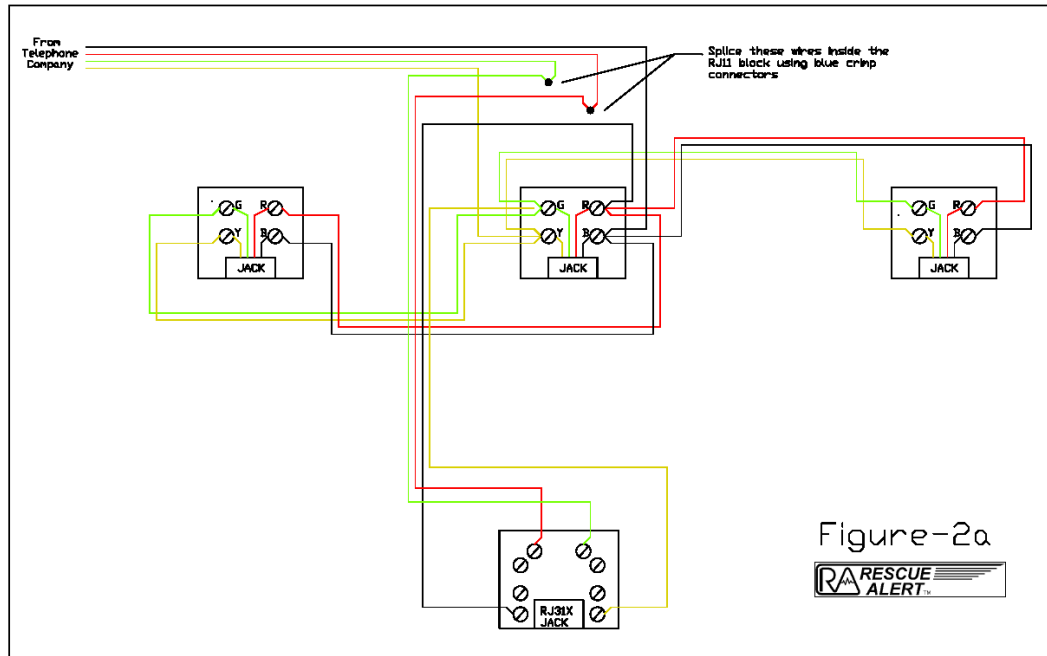

Figure-2a shows an RJ31X jack installed near the entry jack where the wiring goes to more than one additional RJ11 jack as shown in Figure-2.

Instructions:

1. Mount the RJ31X jack on the wall near the existing RJ11 jack using the double back tape supplied with the new jack.
2. Remove the cover of the existing RJ11 jack.
3. Disconnect the RED and GREEN wires coming from the telephone company. Now all telephones in the house should be dead. If any telephone still works, the two wires disconnected are not the feed from the telephone company. Reconnect them and find the correct pair.
4. Splice the loose RED and GREEN wires to the RED and GREEN wires coming from the RJ31X jack using two blue crimp connectors.
5. Connect the YELLOW and BLACK wires from the RJ31X jack to the terminals where the original RED and GREEN feed wires were connected. All telephones in the house should now be operational again.
6. Tuck the wires back into the RJ11 housing and replace the cover.
7. Connect the RA400 to the new RJ31X jack using the RA400 RJ31X Cable supplied in the kit.

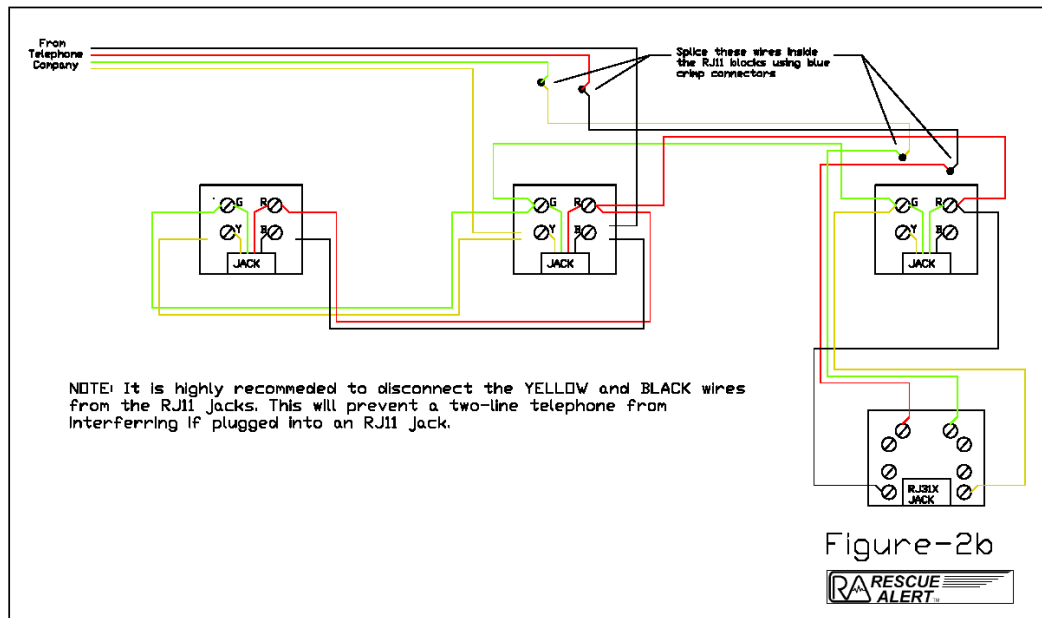

Figure-2b shows an RJ31X jack installed near a jack other than the entry jack in a home originally wired as shown in Figure-2.

Instructions:

1. Mount the RJ31X jack on the wall near the desired RJ11 jack using the double back tape supplied with the new jack.
2. Remove the cover of the RJ11 jack.
3. At the entry jack, disconnect the RED and GREEN feed wires coming from the telephone company. Now all telephones in the house should be dead. If any telephone still works, the two wires disconnected are not the feed from the telephone company. Reconnect them and find the correct pair.
4. Remove all of the YELLOW and BLACK wires leaving the RJ11 jack going to the next jack in the daisy chain.
5. Splice the loose RED wire to the loose BLACK wire and the loose GREEN wire to the loose YELLOW wire using two blue crimp connectors as shown in Figure-2b.
6. At the next jack in the branch, remove each YELLOW and BLACK wire from the RJ11 jack and splice the wires together (YELLOW to YELLOW and BLACK to BLACK). Repeat this step for all jacks in the house except the jack where the RJ31X is being installed. If at the end of a branch, disconnect the YELLOW and BLACK wires and cut off the bare ends so they do not short or touch any other connection.

7. At the jack where the RJ31X is being installed, disconnect the YELLOW and BLACK wires from the RJ11 as shown in Figure-2b.
8. Splice the YELLOW wire that was just disconnected to the GREEN wire that is coming from the RJ31X using a blue crimp connector.
9. Splice the BLACK wire that was just disconnected to the RED wire coming from the RJ31X using a blue crimp connector.
10. Connect the BLACK wire from the RJ31X jack to the RED terminal of the RJ11 jack as shown in Figure-2b.
11. Connect the RED wire from the RJ31X jack to the GREEN terminal of the RJ11 jack as shown in Figure-2b.
12. At this point, each telephone in the house should be operational.
13. Tuck the wires back into all of the RJ11 housings and replace the covers.
14. Connect the RA400 to the new RJ31X jack using the RA400 RJ31X Cable supplied in the kit.